

4. EV Board Schematic

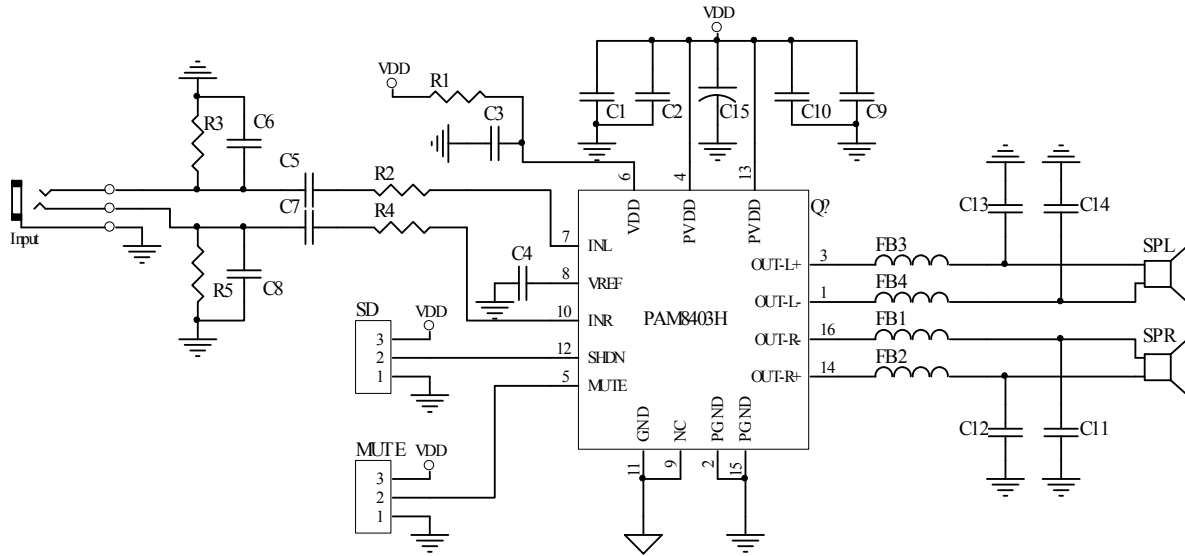

Figure 1

5. PAM8403 EB04AB EVB Description

PAM8403 EB04AB is an evaluation board for the PAM8403H, a stereo class-D audio power amplifier. The board is targeted to be used in providing a simple and convenient evaluation environment for the PAM8403H. Requires parts, the standard RCA jacks for audio inputs, pin jacks for power supply and signal outputs etc. on the board make it easy to be evaluated.

6. EV Board View and Jack Description

Top View

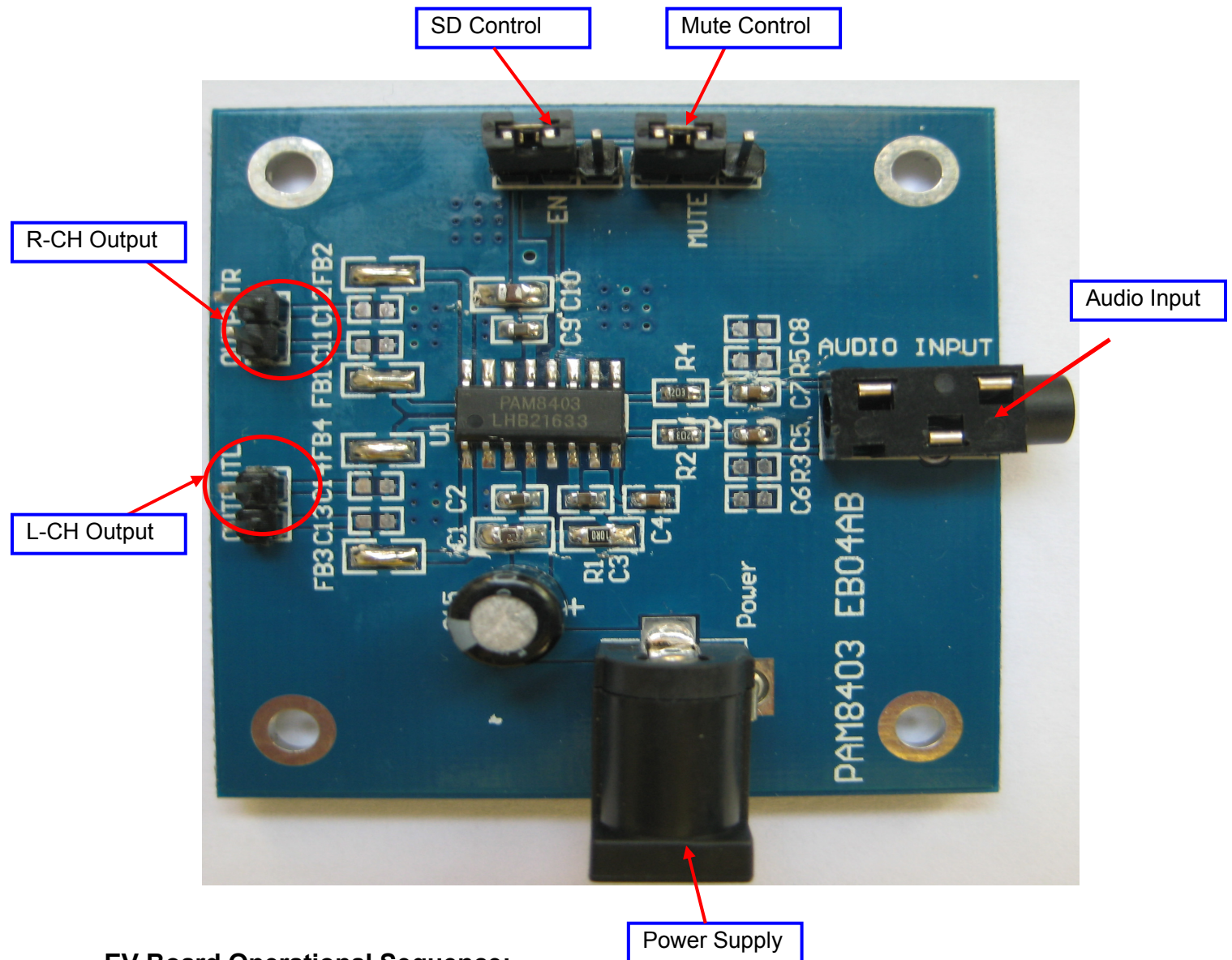

EV Board Operational Sequence:

- Connect SD to a high for normal operation
- Connect audio input from audio input jack
- Connect the loading (speaker or power resistor) to the output jack
- Power on: 2.5V to 5.5V DC power supply

7. EV Board BOM List

Item	Value	Type	Rating	Description	Vender and port
C5,C7	0.47μF	X5R/X7R, Ceramic/0603	25V	Input coupling CAP	TMK107B7474KA-TR
C2,C9	1μF	X5R/X7R, Ceramic/0603	25V	VDD coupling CAP,	TMK107B7105KA-T
C1,C10	10μF	X5R/X7R, Ceramic/0805	25V	VDD main coupling CAP,	TMK316AB7106KL-T
C4	0.1μF	X5R/X7R, Ceramic/0603	25V	VREF CAP	UMK212B7104KG-T
C3	1μF	X5R/X7R, Ceramic/0603	25V	Decoupling CAP	TMK107B7105KA-T
C15	220μF		10V	Decoupling CAP	
R1, R2	20K		1%	Input Resistor	
R3, R5		NC			
C6,C8		NC			
FB1,FB2, FB3,FB4	330Ω	0805	2A	For EMI eliminate components form a FB-CAP filter	Wurth 724 792 037
C11,C12, C13,C14	1nF	0603	25V		TMK063B7102KP-F

8. External Components Selection

Input Capacitors (C5, C7)

- (1) Form a high pass filter with R_i , and the cut off frequency is $f_c = 1/2 \cdot \pi \cdot R_i \cdot C_i$
- (2) Have a tolerance of 10% or better for matching: any mismatch in capacitance causes an importance mismatch at the corner frequency and below
- (3) Low leakage current needed, 0.47μF, X5R/X7R ceramic recommend

Input Resistors (R2, R4)

- (1) Limit the closed-loop gain
- (2) Form a high pass filter with C_i , and the cut off frequency is $f_c = 1/2 \cdot \pi \cdot R_i \cdot C_i$
- (3) 1% tolerance needed for resistor matching to improve CMRR, PSRR

Power Supply decoupling Caps (C2, C3, C9, C1, C10)

- (1) Low ESR for good THD, PSRR
- (2) 1uF ceramic for higher frequency transients, spikes, or digital hash on the line of PVDD/VDD
- (3) Additional 10μF or greater for low frequency noise filtering and serves as a local storage capacitor for supplying current during large signal transients on the amplifier outputs
- (4) Need place very closed to the IC

VREF Capacitor (C4)

- (1) 1μF, X5R/X7R ceramic recommended
- (2) Place very closed to the device

EMI Eliminate Filter (FB1, FB2, FB3 and FB4)

- (1) High impedance at high frequency and very low impedance at low frequency
- (2) The current rating is higher than 2A

9. PCB Layout Guidelines

Grounding

- (1) Use plane grounding or separate grounds
- (2) Do not use one line connecting power GND and analog GND
- (3) Output noise grounds must tie to system ground at the power in exclusively.
- (4) Signal currents for the inputs need to be returned to quiet ground. This ground only ties to the signal components and the GND pin.

Power Supply

Others

- (1) The power supply capacitors (C2, C3, C9, C1, C10) need to place very close to the PAM8003's pins.
- (2) Input capacitors (C5, C7) place closed to input pin as near as possible

10. PCB Layout Example

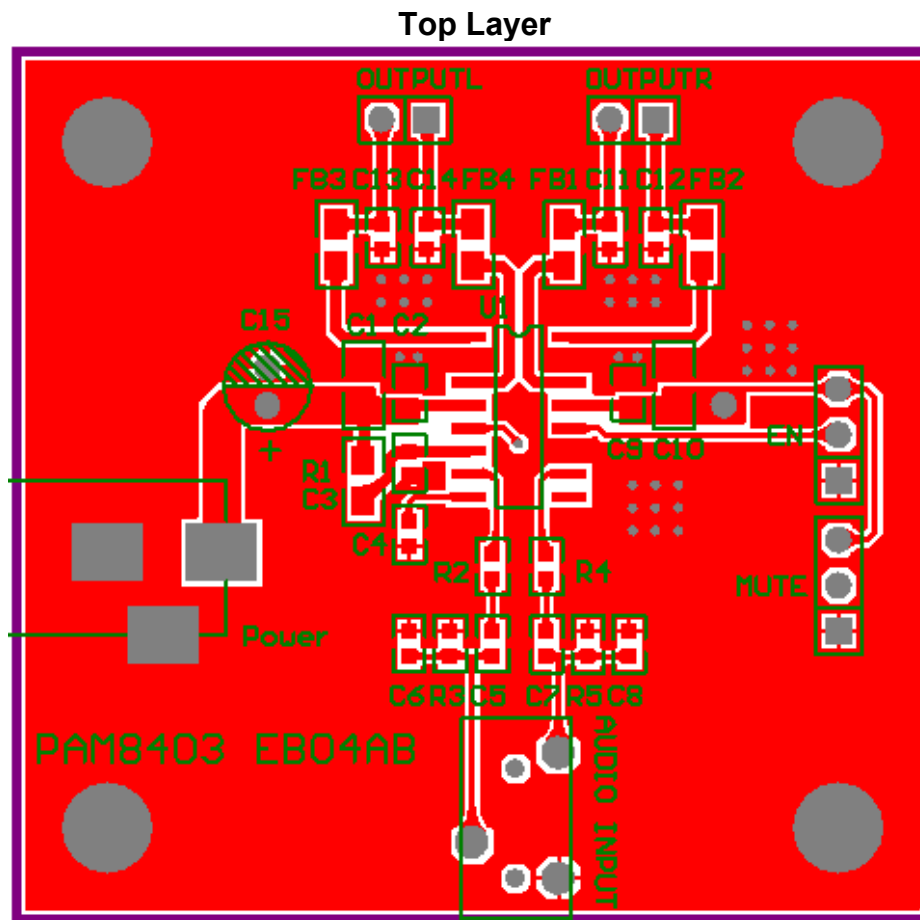

Bottom Layer

